

伸缩活接头

● PVC, C-PVC 20 - 100mm (3/4 inch - 4 inch)

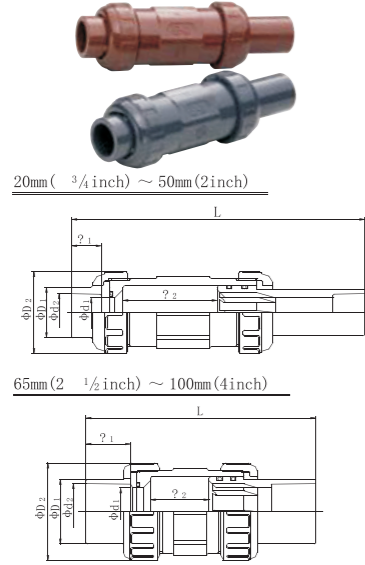

特点

- 伸缩空间大
- 只需拧松螺母就能拆卸
- 简约设计, 不占用排管空间

规格表

材质	工作温度	最大工作压力 MPa[kgf/cm2][PSI]	接口方式
PVC	0°C - 50°C (30°F - 120°F)	1.0{10.2}[150]	插口式
CPVC	0°C - 90°C (30°F - 195°F)	1.0{10.2}[150]	插口式

伸缩活接头

单位:MPa(kgf/cm2)

材质		PVC			C-PVC		
温度 C		PVC			C-PVC		
mm	inch	0 - 40	41 - 50	5 - 40	41 - 60	61 - 70	71 - 90
20 - 100	3/4 - 4	1.0{10.2}	0.6{6.1}	1.0{10.2}	0.6{6.1}	0.4{4.1}	0.2{2.0}

尺寸表

JIS		单位: mm									
口径	mm	inch	d ₁	d ₂	ℓ ₁	1/T	D ₁	D ₂	L		ℓ ₂
									Max	Min	
20	3/4	20	26.13	24	1/34	35	60	243	163	80	
25	1	25	32.16	27	1/34	43	70	250	170	80	
30	1 1/4	31	38.19	30	1/34	50	82	258	178	80	
40	1 1/2	40	48.21	37	1/37	59	100	272	192	80	
50	2	51	60.25	42	1/37	72	106	285	205	80	
65	2 1/2	65	76.60	61	1/48	88	133	314	234	80	
80	3	78	89.60	64	1/49	105	152	330	250	80	
100	4	100	114.70	84	1/56	132	210	422	322	100	

DIN		单位: mm									
口径	mm	inch	d ₁	d ₂	ℓ ₁	D ₁	D ₂	L		ℓ ₂	
								Max	Min		
20	3/4	20	25	19	35	60	237	157	80		
25	1	25	32	22	43	70	244	164	80		
30	1 1/4	—	—	—	—	—	—	—	—		
40	1 1/2	40	50	31	59	100	262	182	80		
50	2	51	63	38	72	106	271	191	80		
65	2 1/2	—	—	—	—	—	—	—	—		
80	3	78	90	51	105	152	313	233	80		
100	4	100	110	61	132	210	388	308	100		

☆ CPVC/PVC管道热膨胀一览表

A: 管道尺寸
B: 温度

B	A	单位: mm							
		5 m	10 m	20 m	30 m	40 m	50 m	60 m	70 m
10°C	4	7	14	21	28	35	42	49	56
20°C	7	14	28	42	56	70	84	98	112
30°C	11	21	42	63	84	105	126	147	168
40°C	14	28	56	84	112	140	168	196	224
50°C	18	35	70	105	140	175	210	245	280
60°C	21	42	84	126	168	210	252	294	336
70°C	25	49	98	147	196	245	294	343	392
80°C	28	56	112	168	224	280	336	392	448

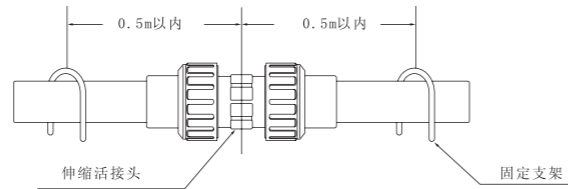

AV法兰

● TS法兰 (PVC, HI-PVC, C-PVC)

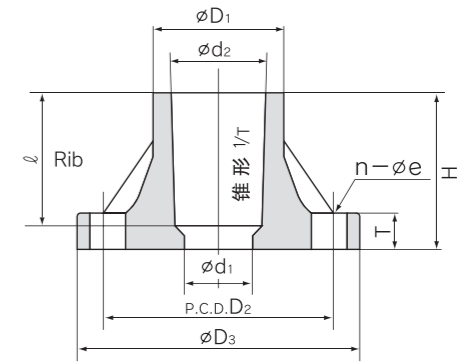
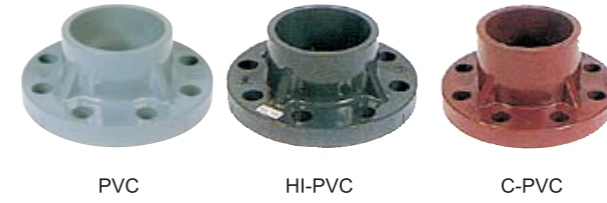

尺寸表

AV法兰		PVC		JIS 10K 13mm - 350mm (3/8 inch - 14 inch)		JIS 5K 13mm - 350mm (3/8 inch - 14 inch)		HI-PVC		JIS 10K 13mm - 250mm (3/8 inch - 10 inch)		JIS 5K 13mm - 150mm (3/8 inch - 6 inch)										
JIS														单位: mm								
口径	d ₁	d ₂		锥形 1/T		ℓ		D ₁		D ₂		D ₃		n		e		T		H		
mm	inch	10K	5K	10K	5K	10K	5K	10K	5K	10K	5K	10K	5K	10K	5K	10K	5K	10K	5K	10K	5K	
13	3/8	15	18.40	1/30		26		25.5	24	65	55	90	75	4	4	15	12	14	9	30	30	
15	1/2	18	22.40	1/34		30		31	29	70	60	95	80	4	4	15	12	14	9	35	35	
20	3/4	22	26.45	1/34		35		35	33	75	65	100	85	4	4	15	12	15	10	40	40	
25	1	25	32.55	1/34		40		42.5	40	90	75	125	95	4	4	19	12	15	10	46	45	
32	1 1/4	30	38.60	1/34		44		48.5	46	100	90	135	115	4	4	19	15	16	12	50.5	50	
40	1 1/2	41	48.70	1/37		55		60.5	59	105	95	140	120	4	4	19	15	16	12	61.5	61	
50	2	52	60.80	1/37		63		73	70	120	105	155	130	4	4	19	15	20	14	71	72	
65	2 1/2	67	76.60	76.80	1/48	1/41	61	69	90	86	140	130	175	155	4	4	19	15	22	14	70	76
80	3	78	89.60	89.80	1/49	1/43	64	72	105	101	150	145	185	180	8	4	19	19	22	14	73	80
100	4	100	114.70	115.00	1/56	1/44	84	92	131	129	175	165	210	200	8	8	19	19	22	16	93	105
125	5	125	140.85	141.20	1/58	1/45	104	112	158	156	210	200	250	235	8	8	23	19	24	16	114	126
150	6	146	166.00	166.50	1/63	1/45	132	140	185	185	240	230	280	265	8	8	23	19	26	18	142	150
200	8	196	217.00	—	1/50	—	145	238	238	290	280	330	320	12	8	23	23	28	28	156	156	
250	10	247	268.00	—	1/55	—	155	289	289	355	345	400	385	12	12	25	23	30	30	167	167	
300	12	298	318.70	—	1/55	—	155	341	341	400	390	445	430	16	12	25	23	30	30	167	167	
350	14	348	371.00	—	1/60	—	230	398	398	445	435	490	480	16	12	25	23	34	34	300	300	

AV法兰		C-PVC JIS 10K 13mm - 150mm (3/8 inch - 6 inch), JIS 5K 13mm - 65mm (3/8 inch - 2 1/2 inch)																	
JIS														单位: mm					
口径	d ₁	d ₂	Taper 1/T	ℓ	D ₁		D ₂		D ₃		n		e		T		H		
mm	inch	10K	5K	10K	5K	10K	5K	10K	5K	10K	5K	10K	5K	10K	5K	10K	5K	10K	5K
13	3/8	15	18.40	1/30	26	28	24	65	55	90	75	4	4	15	12	14	9	30	30
15	1/2	18	22.40	1/34	30	33	31	70	60	95	80	4	4	15	12	14	9	35	35
20	3/4	22	26.45	1/34	35	36	33	75	65	100	85	4	4	15	12	14	10	40	40
25	1	25	32.55	1/34	40	43	43	90	75	125	95	4	4	19	12	16	10	50	45
32	1 1/4	30	38.60	1/34	44	51	51	100	90	135	115	4	4	19	15	16	12	50.5	50
40	1 1/2	41	48.70	1/37	55	65	65	105	95	140	120	4	4	19	15	16	12	65	61
50	2	52	60.80	1/37	63	76	76	120	105	155	130	4	4	19	15	20	14	74	72
65	2 1/2	67	76.80	1/41	69	92	86	140	130	175	155	4	4	19	15	22	14	82	76
80	3	78	89.80	1/43	72	108	—	150	—	185	—	8	—	19	—	22	—	86	—
100	4	100	115.00	1/44	92	138	—	175	—	210	—	8	—	19	—	22	—	105	—
125	5	125	141.20	1/45	112	165	—	210	—	250	—	8	—	23	—	22	—	126	—
150	6	146	166.00	1/63	132	185	—	240	—	280	—	8	—	23	—	26	—	142	—

• AV 法兰 (PVC,PP)

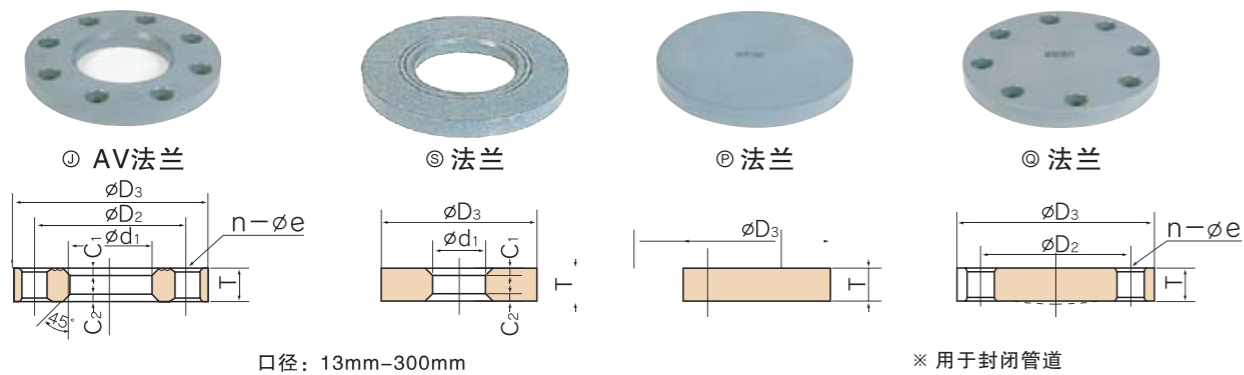

口径: 13mm-300mm

※ 用于封闭管道

尺寸表

口径		d ₁	D ₂		D ₃		n		e		T		C ₁	C ₂
mm	inch		10K	5K	10K	5K	10K	5K	10K	5K	10K	5K		
13	3/8	18	65	55	90	75	4	4	15	12	12	9	3	3
15	1/2	22	70	60	95	80	4	4	15	12	12	9	3	3
20	3/4	26	75	65	100	85	4	4	15	12	14	10	3	3
25	1	32	90	75	125	95	4	4	19	12	14	10	3	3
32	1 1/4	38	100	90	135	115	4	4	19	15	16	12	3	3
40	1 1/2	48	105	95	140	120	4	4	19	15	16	12	3	3
50	2	60	120	105	155	130	4	4	19	15	16	14	3	4
65	2 1/2	76	140	130	175	155	4	4	19	15	18	14	3	4
80	3	89	150	145	185	180	8	4	19	19	18	14	3	4
100	4	114	175	165	210	200	8	8	19	19	18	16	3	4
125	5	140	210	200	250	235	8	8	23	19	20	16	4	4
150	6	165	240	230	280	265	8	8	23	19	22	18	4	4
200	8	216	290	280	330	320	12	8	23	23	22	20	4	4
250	10	267	355	345	400	385	12	12	25	23	24	22	4	4
300	12	318	400	390	445	430	16	12	25	23	24	22	4	4

AV 垫圈

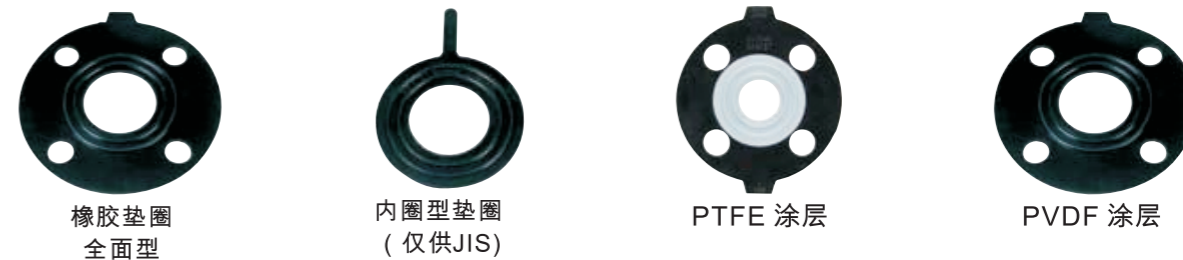

• 材质: EPDM, PTFE, PVDF, CSM, FKM, IIR, Viton F, C

特点

- AV垫片采用一次成形, 分布均匀表面光泽平滑。
- 特设二条热圈形状的凸起部位, 即使面压较低也不会泄漏。
- 橡胶硬度适当, 有益于缓冲, 热应力和排管应力。
- 以纯度上乘的橡胶为原料, 使用寿命增长。

规格表

材质	工作温度	标准有效尺寸	
		JIS	DIN
EPDM	- 40°C - 90°C	15mm - 350mm	15mm - 350mm
PTFE	- 40°C - 120°C	15mm - 300mm	15mm - 400mm
PVDF	- 40°C - 120°C	15mm - 300mm	15mm - 300mm
VIFLON	- 5°C - 150°C	15mm - 200mm	-

尺寸图

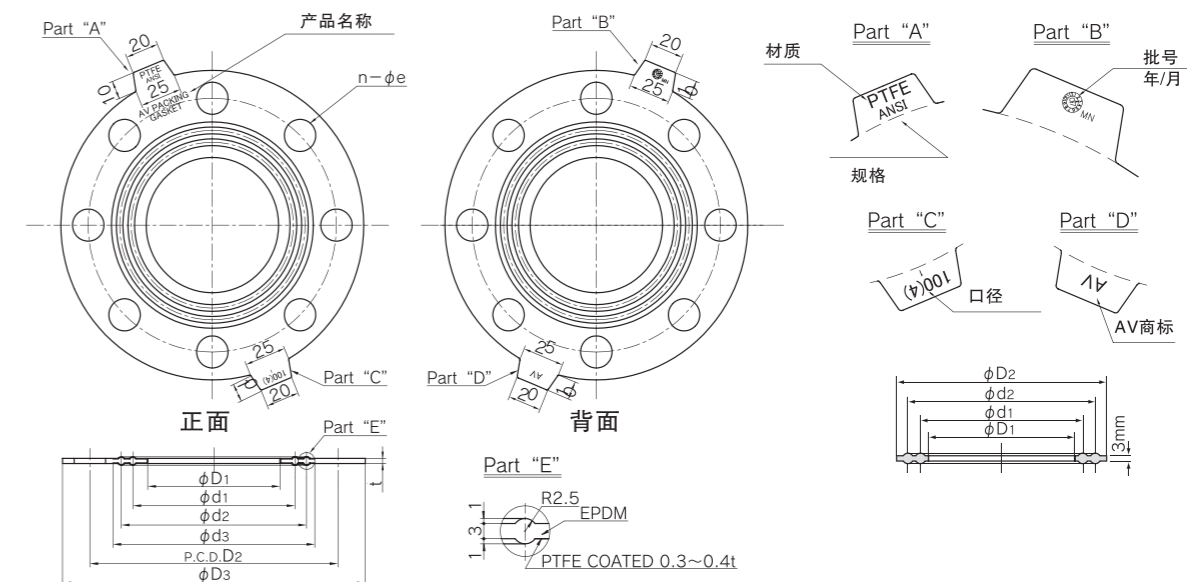

类别	口径	厚度
PTFE	15mm(1/2inch) to 400mm(16inch)	0.3-0.4mm(0.012-0.016inch)
PVDF	15mm(1/2inch) to 65mm(2 1/2inch) 80mm(3inch) to 300mm(12inch)	0.4-0.5mm(0.016-0.020inch)

尺寸表

全面型 (JIS10K)								单位: mm	
口径		D ₁	D ₂	D ₃	n	e	d ₁	d ₂	
mm	inch								
13	3/8	15	65	88	4	15	22	37	
15	1/2	18	70	93	4	15	26	41	
20	3/4	22	75	98	4	15	32	47	
25	1	30	90	123	4	19	38	53	
32	1 1/4	37	100	133	4	19	50	65	
40	1 1/2	43	105	138	4	19	54	69	
50	2	54	120	153	4	19	68	83	
65	2 1/2	69	140	173	4	19	86	101	
80(75)	3	80	150	183	8	19	98	112	
100	4	102	175	208	8	19	120	138	
125	5	127	210	248	8	23	145	166	
150	6	150	240	278	8	23	168	190	
200	8	198	290	328	12	23	216	247	
250	10	249	355	398	12	25	270	306	
300	12	300	400	443	16	25	324	352	
350	14	350	445	488	16	25	370	390	

内圈型 (JIS10K)					单位: mm	
口径		D ₁	D ₂	d ₁	d ₂	
mm	inch					
15	1/2	18	54	26	41	
20	3/4	22	59	32	47	
25	1	30	70	38	53	
32	1 1/4	37	80	50	65	
40	1 1/2	43	85	54	69	
50	2	54	100	68	83	
65	2 1/2	69	120	86	101	
80(75)	3	80	130	98	112	
100	4	102	155	120	138	
125	5	127	187	145	166	
150	6	150	217	168	190	
200	8	198	267	216	247	
250	10	249	329	270	306	
300	12	300	374	324	352	

全面型 (DIN2501)								单位: mm	
口径		D ₁	D ₂	D ₃	n	e	d ₁	d ₂	
mm	inch								
15	1/2	18	65	93	4	14	26	41	
20	3/4	22	75	103	4	14	32	47	
25	1	30	85	113	4	14	38	53	
32	1 1/4	37	100	138	8	18	50	65	
40	1 1/2	43	110	148	4	18	54	69	
50	2	54	125	163	4	18	68	83	
65	2 1/2	69	145	183	4	18	86	101	
80(75)	3	80	160	198	8	18	98	112	
100	4	102	180	218	8	18	120	138	
125	5	127	210	248	8	18	145	166	
150	6	150	240	283	8	23	168	190	
200	8	198	295	338	8	23	216	247	
250	10	249	350	393	12	23	270	306	
300	12	300	400	443	12	23	324	352	
350	14	350	460	503	16	25	370	390	
400	16	407	515	563	16	26	442	472	

旋拧力矩 (所有材质/全面型)

mm(inch)	N. m	FT-LB	mm(inch)	N. m	FT-LB	mm(inch)	N. m	FT-LB
15 (1/2)	17.5	13	65 (2 1/2)	22.5	16	200 (8)	55	40
20 (3/4)	17.5	13	80 (3)	30	22	250(10)	55	40
25 (1)	20	14	100(4)	30	22	300(12)	60	43
40 (1 1/2)	20	14	125(5)	40	29	350(14)	60	43
50 (2)	22.5	16	150(6)	45	32	400(16)	80	58

DV接头

- DV接头 (JISK6739)
(口径: 40 ~ 150mm)



特点

弯头 (DL)	30 - 150mm
大弯头 (LL)	40 - 150mm
弯头 (45L)	30 - 150mm
Y型三通 (DT)	30 - 150x100mm
Y型大三通	40 - 150x125mm
两侧Y型大三通 (WLT)	65 - 125x100mm
Y型三通 (Y)	40 - 150x100mm
直通 (DS)	40 - 150mm
套筒 (IN)	40x30 - 150x125mm

粘合剂



AV粘合剂NO.32
100g, 500g, 1kg

AV粘合剂NO.52
500g

AV粘合剂NO.62
1kg

AV粘合剂NO.88
250, 500g

AV粘合剂NO.90
500g

※ 注意事项

AV粘合剂属于易燃危险品, 使用及保存请注意安全。
使用前请仔细阅读并遵守罐体上标注的注意事项。

特点

- AV粘合剂No.32, NO52用于小口径AVTS法兰管件等
- AV粘合剂No.62适用于大口径管件
- AV粘合剂No.88适用于耐热管件(CPVC)
- AV粘合剂No.90适用于HI系列管件

规格表

名称	类别	罐体颜色	黏度 (CP)	干燥缩率(%)	粘合强度 (kgf/cm ²)	
					15分钟后	2小时后
AV No.32	低粘度, 快干	蓝	100 - 250	30 - 50	12.5以上	25以上
AV No.52	高粘度, 快干	红	800 - 1,500	30 - 50	12.5以上	25以上
AV No.62	高粘度, 慢干	黄	500 - 1,500	10 - 30	-	15以上
AV No.88	低粘度, 快干	棕	200 - 700	-	-	-
AV No.90	低粘度, 快干	深蓝	500 - 800	30 - 50	12.5以上	25以上

AV粘合剂必要消耗量 (用于连接PVC管道与PVC接头)

口径		13	16	20	25	30	40	50	65	75	100	125	150	200	250	300	350	400	450	500
涂抹量		0.9	1.2	1.7	2.0	3.1	5.0	7.1	9.9	12.0	20	30	44	81	126	180	244	318	400	490
适用型号	夏季	• No. 32 或 No. 52												• No. 62						
	冬季	• No. 32												• No. 52 或 No. 62						